

MCT STOPS FIRE, GASES, WATER, FUMES, AND WORRY.

Multi-Cable Transit



TERASAKI



 TERASAKI ELECTRIC CO., LTD.

The Multi-Cable Transit system is a proven fireproof, water and airtight method of passing cables from one compartment to another. It is simple, expedient and economical-giving much more protection than conventional stuffing tubes while drastically reducing time and installation cost.

Applications:

- Watertight, airtight, fireproof bulkhead and deck penetrations
- Weather deck penetrations
- Electrical equipment penetrations
- Fire and explosion-proofing of critical areas
- Thermal barrier for all penetrations
- Sound and vibration-free entries for cables and pipes

Principal Features Of Multi-Cable Transit

■ FIRE AND SMOKE PROOF

In the event of fire, specially formulated elastomer insert blocks expand. A firm incombustible seal is formed around the burning cables, filling in all parts destroyed by fire and choking off any passage of fire or smoke.

■ WATER AND AIRTIGHT

When compressed around cables, Multi-Cable Transit insert blocks form an absolute water and airtight seal.

■ SHOCK AND VIBRATION PROOF

Interlocking of assembled components prevents dislodgement under conditions of shock and vibration.

■ ECONOMICAL

Cable-pulling time and cost are considerably reduced by the insertion of cables through wide open transit frames in lieu of stuffing tubes.

■ GREATER FLEXIBILITY

From design to final system check out, Multi-Cable Transit gives greater accuracy in estimating and laying out cable runs. Cables can easily be added, removed, or sizes changed at any time.

■ SPACE SAVING

A greater number of cables can be grouped in smaller areas.

■ CABLE PROTECTION

Multi-Cable Transit prevents chafing or shredding of cable, since cables are not pulled through small apertures. The very nature of the insert blocks protects the cables from rubbing and rusting at all penetration points.

■ POSITIVE VISUAL INSPECTION

There is no hidden sealing of components or material. All units can be readily inspected, assuring, that a tight seal has been made against fire, water, air, dust, etc.

Can Supply MCT that is:

SOLAS Class "A-60"
 Fire rating 1 hour for bulkheads and decks.
 Please ask for details of the certificate required.

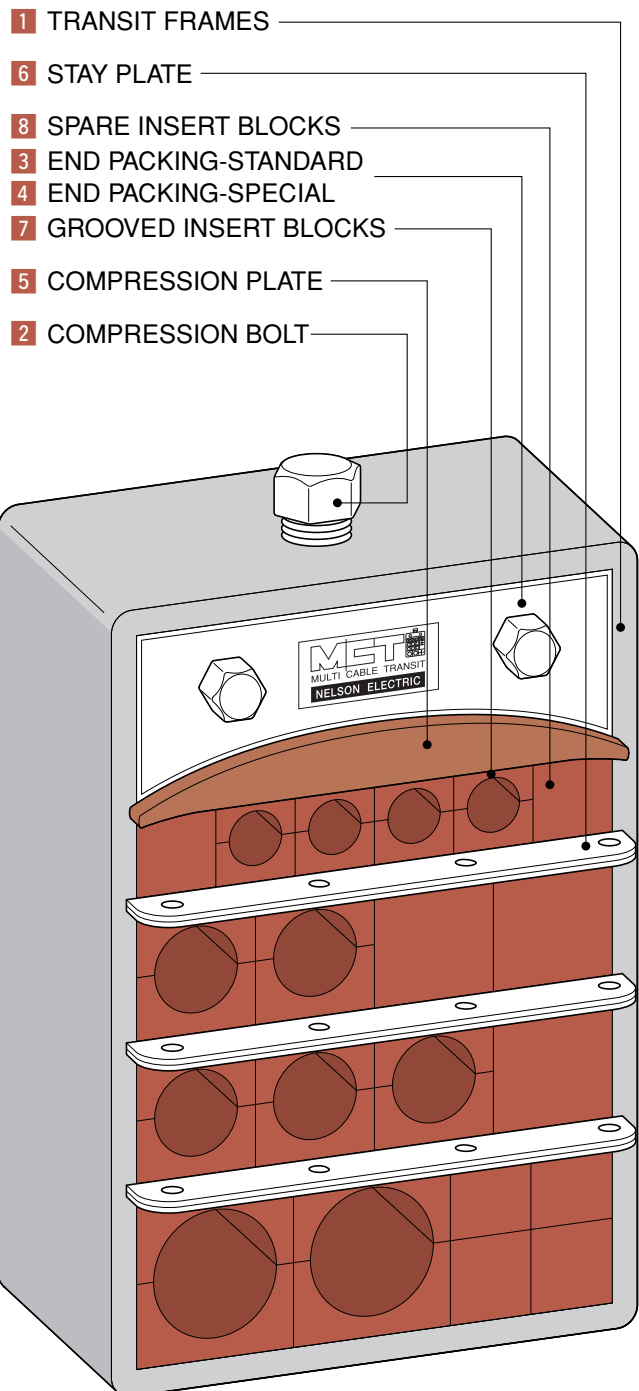

1 FRAME DIMENSTIONS

STANDARD

unit : mm

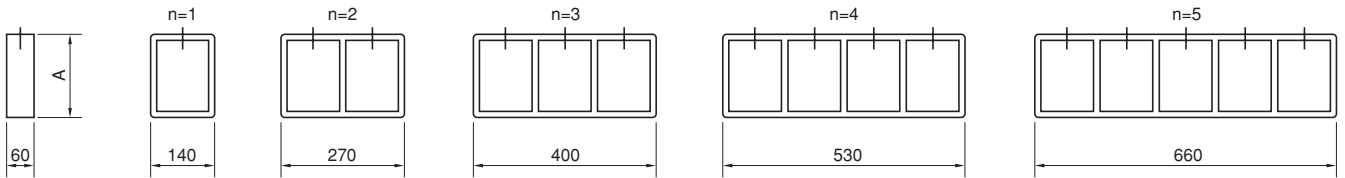

| n = 1 | n = 2 | n = 3 | n = 4 | n = 5 | A |
|-------|--------|--------|--------|--------|-----|
| RGS-2 | RGS-22 | RGS-23 | RGS-24 | RGS-25 | 121 |
| RGS-4 | RGS-42 | RGS-43 | RGS-44 | RGS-45 | 180 |
| RGS-6 | RGS-62 | RGS-63 | RGS-64 | RGS-65 | 238 |

TANDEM

unit : mm

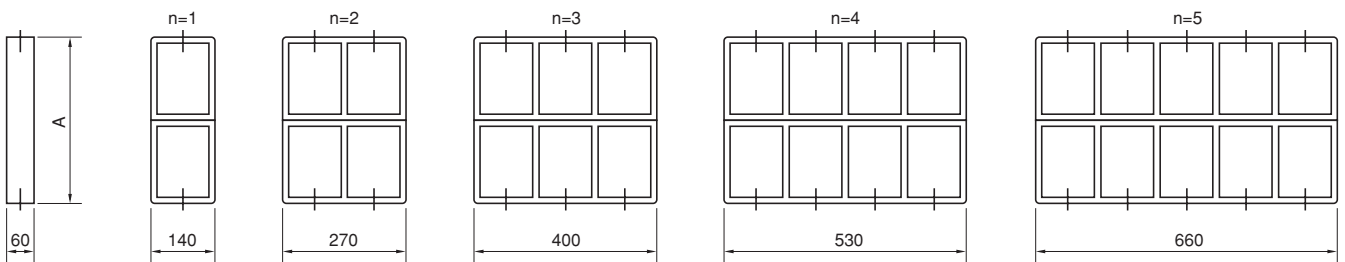

| n = 1 | n = 2 | n = 3 | n = 4 | n = 5 | A |
|--------|---------|---------|---------|---------|-----|
| RGS-2T | RGS-22T | RGS-23T | RGS-24T | RGS-25T | 242 |
| RGS-4T | RGS-42T | RGS-43T | RGS-44T | RGS-45T | 360 |
| RGS-6T | RGS-62T | RGS-63T | RGS-64T | RGS-65T | 476 |

with FRANGE

unit : mm

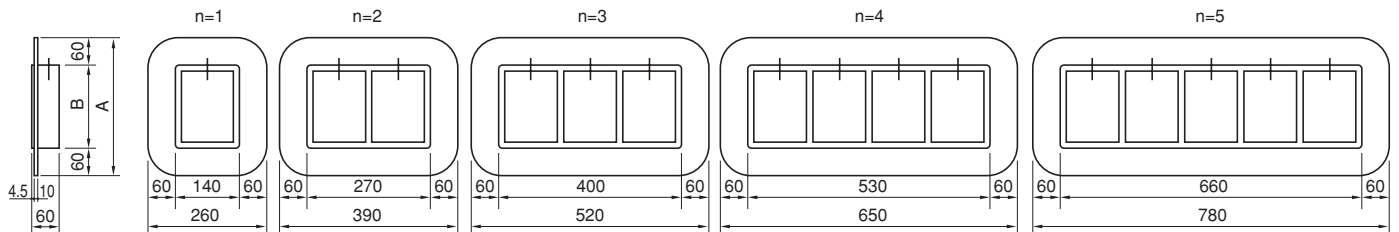

| n = 1 | n = 2 | n = 3 | n = 4 | n = 5 | A | B |
|--------|---------|---------|---------|---------|-----|-----|
| RGS-2F | RGS-22F | RGS-23F | RGS-24F | RGS-25F | 241 | 121 |
| RGS-4F | RGS-42F | RGS-43F | RGS-44F | RGS-45F | 300 | 180 |
| RGS-6F | RGS-62F | RGS-63F | RGS-64F | RGS-65F | 358 | 238 |

TANDEM with FRANGE

unit : mm

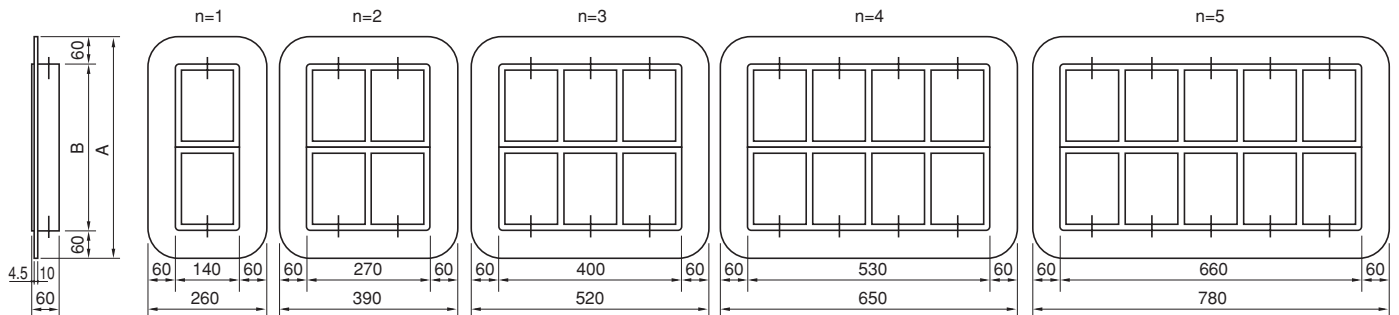

| n = 1 | n = 2 | n = 3 | n = 4 | n = 5 | A | B |
|---------|----------|----------|----------|----------|-----|-----|
| RGS-2TF | RGS-22TF | RGS-23TF | RGS-24TF | RGS-25TF | 362 | 242 |
| RGS-4TF | RGS-42TF | RGS-43TF | RGS-44TF | RGS-45TF | 480 | 360 |
| RGS-6TF | RGS-62TF | RGS-63TF | RGS-64TF | RGS-65TF | 596 | 476 |

n=number of frame opening in row

2 COMPRESSION BOLT

When tightened, seats the Compression Plate farther down into the transit frame.

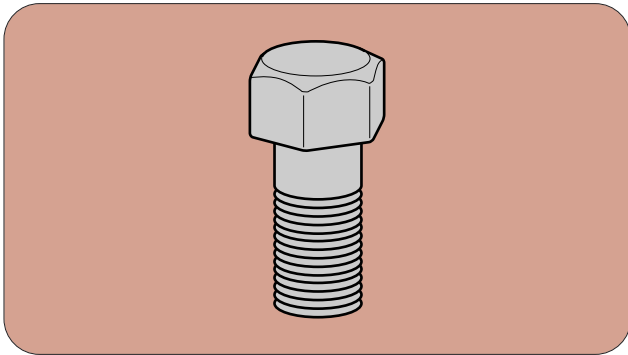

5 COMPRESSION PLATE

Seats and compresses the Insert Blocks so that the End Packing can be inserted in the transit frame.

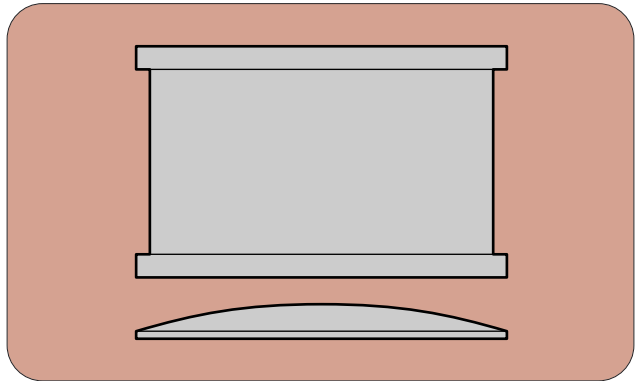

3 END PACKING-STANDARD

Compresses the Insert Blocks, creating a complete seal against fire, water, air, etc.

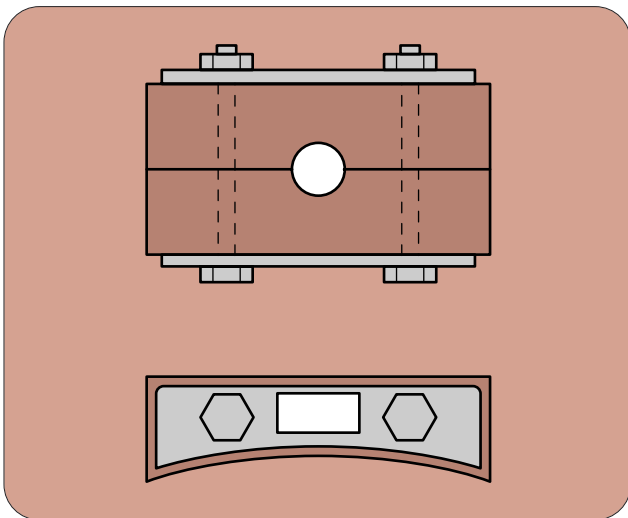

6 STAY PLATE

Stay Plates are normally placed between every other row of Insert Blocks keeping them positioned in the transit frame.

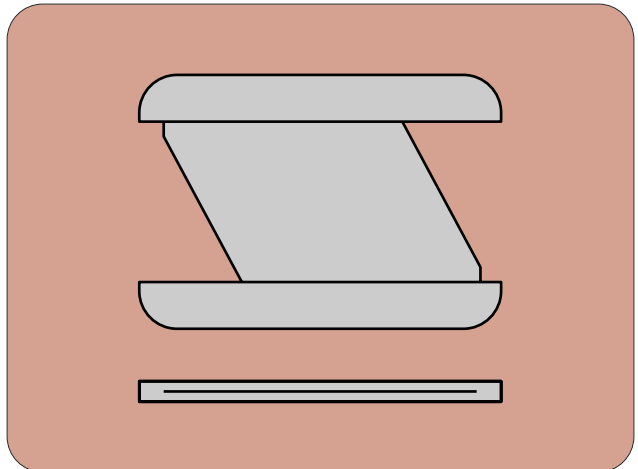

4 END PACKING-SPECIAL

Used when a transit frame can be packed from one side only.

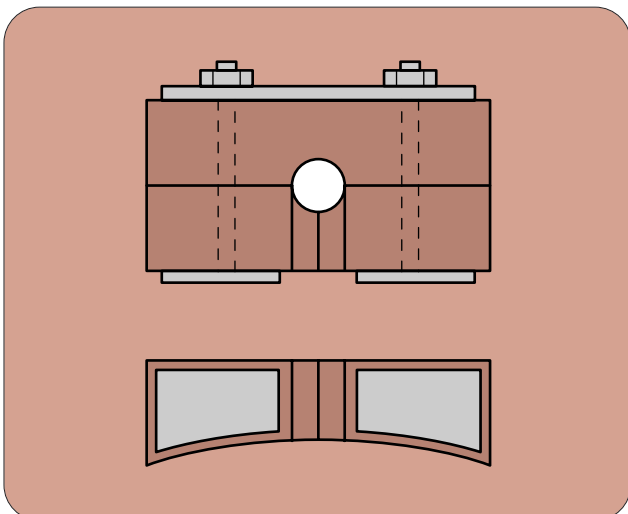

Component Materials

Transit Frames are fabricated either of steel, aluminum, or steel alloys.

Compression Plates are steel or aluminum castings.

Compression Bolts are available in stainless steel or galvanizes.

Stay Plates are made of steel or aluminum.

Insert Blocks and End Packings are made from a specially formulated fire-proof elastomer.

7 GROOVED INSERT BLOCKS

Twin half blocks of specially formulated elastomer with a centered semi-circular groove. When matched around a cable, these half blocks form a single block with a tight fit. Insert blocks are available in 7 basic module sizes accommodating an extensive range of cable sizes from 4mm to 100mm.

8 SPARE INSERT BLOCKS

These solid blocks of elastomer are used to fill voids or to allow for the addition of cables at a future date. They are available in two sizes, 20/0 and 30/0. They may be used in any combination to match the six Grooved Insert Block sizes.

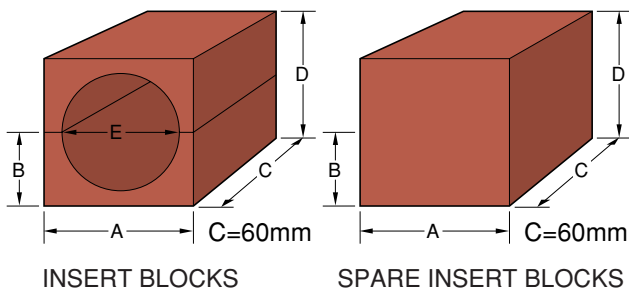

FILL-IN INSERT BLOCKS

These blocks fill in spaces caused by the presence of different-sized blocks in the same row or can be used to increase the pressure in the Transit Frame when exceptionally soft cables are employed. Serrations allow them to be sliced off to desired length.

FILL-IN INSERT BLOCKS (12 X 10/0)



FOR ARMORED CABLE

It is recommended that Sealer be applied in the grooves of each block to seal the space between the armor and cable sheath.

INSERT BLOCK LUBRICANT

Insert Block Lubricant is used when packing Multi-Cable Transits. It allows the blocks to slide easily over each other when packing and compressing them around cables.

DEMENTIONS OF BLOCKS (mm)

| MODULE 20 | | MODULE30 | | MODULE40 | | MODULE60 | | MODULE90 | | MODULE120 | | SPARES | FILL-INS |
|---------------------|----|---------------------|----|---------------------|----|---------------------|----|---------------------|----|---------------------|-----|------------------------|----------|
| A=20 | | A=30 | | A=40 | | A=60 | | A=90 | | A=120 | | 20/0 | 12X10/0 |
| B=10 | | B=15 | | B=20 | | B=30 | | B=45 | | B=60 | | A=20 | A=120 |
| D=20 | | D=30 | | D=40 | | D=60 | | D=90 | | D=120 | | D=20 | D=10 |
| 6=1Row | | 4=1Row | | 3=1Row | | 2=1Row | | 1+30/X =1Row | | 1=1Row | | 6=1Row | 1=1Row |
| Part No. Size mm | E | Part No. Size mm | E | Part No. Size mm | E | Part No. Size mm | E | Part No. Size mm | E | Part No. Size mm | E | 30/0 | |
| 20/4 | 4 | 30/11 | 11 | 40/22 | 22 | 60/32 | 32 | 90/50 | 50 | 120/72 | 72 | A=30 D=30 4=1Row | |
| 20/5 | 5 | 30/12 | 12 | 40/24 | 24 | 60/34 | 34 | 90/52 | 52 | 120/74 | 74 | | |
| 20/6 | 6 | 30/13 | 13 | 40/26 | 26 | 60/36 | 36 | 90/54 | 54 | 120/76 | 76 | | |
| 20/7 | 7 | 30/14 | 14 | 40/28 | 28 | 60/38 | 38 | 90/56 | 56 | 120/78 | 78 | | |
| 20/8 | 8 | 30/15 | 15 | 40/30 | 30 | 60/40 | 40 | 90/58 | 58 | 120/80 | 80 | | |
| 20/9 | 9 | 30/16 | 16 | 40/32 | 32 | 60/42 | 42 | 90/60 | 60 | 120/82 | 82 | | |
| 20/10 | 10 | 30/17 | 17 | 40/34 | 34 | 60/44 | 44 | 90/62 | 62 | 120/84 | 84 | | |
| 20/11 | 11 | 30/18 | 18 | | | 60/46 | 46 | 90/64 | 64 | 120/86 | 86 | | |
| 20/12 | 12 | 30/19 | 19 | | | 60/48 | 48 | 90/66 | 66 | 120/88 | 88 | | |
| 20/13 | 13 | 30/20 | 20 | | | 60/50 | 50 | 90/68 | 68 | 120/90 | 90 | | |
| 20/14 | 14 | 30/21 | 21 | | | 60/52 | 52 | 90/70 | 70 | 120/92 | 92 | | |
| | | 30/22 | 22 | | | 60/54 | 54 | | | 120/94 | 94 | | |
| | | 30/23 | 23 | | | | | | | 120/96 | 96 | | |
| | | 30/24 | 24 | | | | | | | 120/98 | 98 | | |
| | | | | | | | | | | 120/100 | 100 | | |

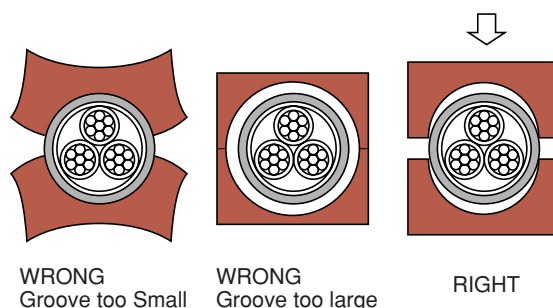

**Installation of Multi-Cable Transit is quick, easy, and economical.
The basic steps are described below:**

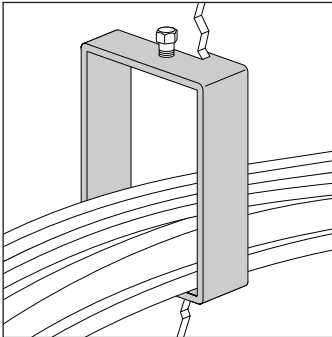

1. Empty Frames are cast into or surface mounted to walls or floors by conventional construction methods. Cables, conduit, or pipe are run according to standard design criteria.

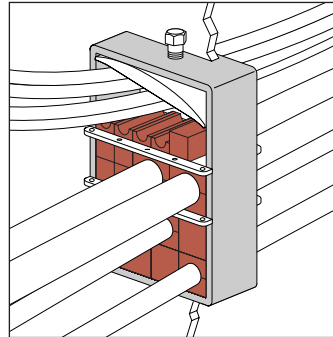

4. Compression plate is inserted and pressed against top end of frame before packing last row of Tecron™ modules.

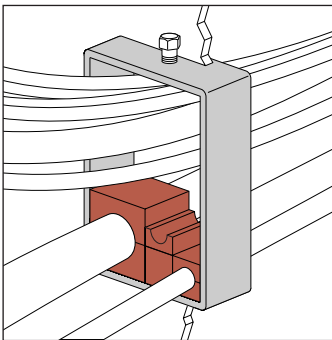

2. Preformed Tecron™ elastomer modules are inserted around each cable, conduit, or pipe.

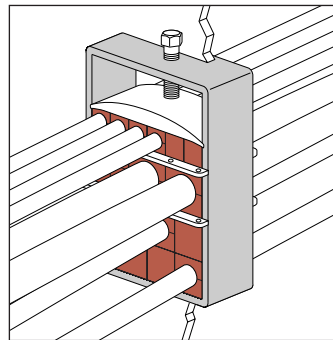

5. When the last row has been packed the compression bolt is tightened until there is space enough to put in the end packing

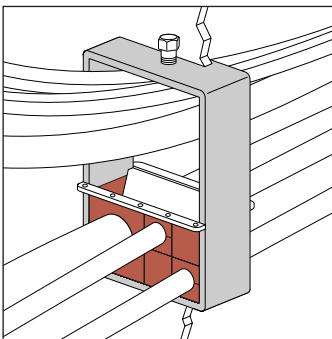

3. Stay plates are placed between rows of Tecron™ modules.

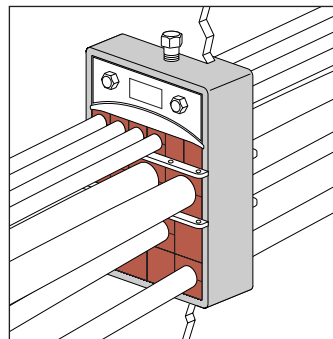

6. Insertion and tightening of end packing completes the job.

PLUG IN

PLUG IN SEALS CABLE PENETRATIONS
REDUCES COST; REDUCES SPACE REQUIREMENTS

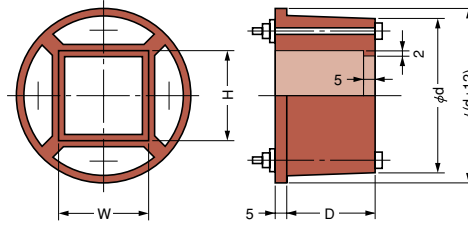

SIZE (unit : mm)

| | W | H | D | ϕd | inside diameter of coaming |
|---------|-----|-----|----|----------|----------------------------|
| RGP-50 | 30 | 30 | 65 | 53 | 53 +2 -0 |
| RGP-75 | 40 | 40 | 65 | 78 | 78 +3 -0 |
| RGP-100 | 60 | 60 | 65 | 102 | 102 +3 -0 |
| RGP-125 | 80 | 80 | 65 | 128 | 128 +3 -0 |
| RGP-150 | 90 | 90 | 65 | 153 | 153 +3 -0 |
| RGP-200 | 120 | 120 | 65 | 202 | 202 +3 -0 |

INSTALLATION INSTRUCTIONS

1. Weld pipe sleeve to bulkhead or deck.
2. Insert Multi-Plugs using tallow. (Plugs are tapered. Insert initially until plug is snug in sleeve.)
3. Cables are pulled through opening (Figure 1).
4. After cable has been pulled, insert blocks are lubricated with tallow. (Provided with plugs.) (Figure 2).
5. Blocks are placed in position (Figure 3)
6. Drive plug and insert blocks fully into sleeve.
7. Nuts are alternately tightened until the Multi-Plug is secure in the sleeve (Figure 4).

Figure 1



Figure 2



Figure 3



Figure 4



Manufacturer

TERASAKI NELSON LTD.
TERASAKI ELECTRIC CO., LTD.

Main Office: 7-2-10, Hannancho, Abenoku, Osaka, Japan / Phone: OSAKA 81-6-6692-1131

Tokyo Office: 1-10-5, Nihonbashimuromachi, Chuoku, Tokyo, Japan / Phone: Tokyo 81-3-3270-2751 / FAX: Tokyo 81-3-3270-8929

OSAKA MCT: 7-2-10, Kamihigashi, Hiranoku, Osaka, Japan / Phone: Osaka 81-6-6791-9347 / FAX: Osaka 81-6-6791-9368

JUL. 2005 - 1.0K

* The contents of this publication may be subject to change without notice.